

Corinex HD200 Powerline Wall Mount F Adapter



*Note: Plug type may vary by region

Introduction

The Corinex HD200 Wall Mount F Adapter series is the latest edition to Corinex's AV200 product family. Supporting transfer rates of up to 200Mbps, the Corinex HD200 Powerline adapter has ample bandwidth to deliver multiple high definition video streams for IPTV service offerings while simultaneously delivering high speed internet access throughout an entire premise! The AV200 Powerline technology by Corinex provides numerous networking possibilities with amazingly fast transfer rates up to 200 Mbps - real world multimedia network applications can be created without adding any new wiring.

In addition to the existing features and functionality of the AV200 series, the HD200 Wall Mount F series of adapters provides the following new features:

- Built in filtered power socket which frees up the wall outlet for other appliances
- Increased transmission line noise immunity – traditional, electrically noisy devices (such as hair dryers) plugged into the Powerline circuit will have less effect on the network data.
- Improved circuit sensitivity – increases the ability of the Powerline adapter to receive network data over longer distances.
- Power Saving Standby Mode/Auto Standby – when not in use, pressing a button can put the adapter in standby mode, minimizing the unit's power usage. The unit will automatically enter standby mode when no network data has been detected over a period of time.

The Corinex HD200 Wall Mount F Adapters allow users to create a high-speed local area network, without the need for new cabling. Users can connect the Powerline adapters to virtually any electrical socket in their home or office to create a

connection to the Powerline network. The network can be connected to an Internet gateway, such as an ADSL or cable modem, providing a convenient extension of the Internet to the Powerline Network. Any ethernet-enabled device, such as a desktop computer, network printer, laptop computer, IPTV, or a security camera can connect to the Powerline network.

Application priority levels are retained, ensuring that applications with real-time requirements, such as VoIP, streaming video, and multiplayer head-to-head games do not experience lag, frame loss, even if other users on the same network are downloading large files, web surfing or downloading and listening to MP3 songs.

Key Features

- Autosensing 10/100 BaseT Fast Ethernet interface in full and half duplex transfer modes
- Filtered Power output socket
- Powerline data rates up to 200Mbps
- QoS – Quality of Service management with 8-level priority queues, programmable priority-classification engine and priority markings to ensure correct traffic prioritization
- Remote programmable notching, ensuring dynamic adaptability to comply with current and future global regulatory requirements
- Powerful 128-bit AES, 256-bit AES and 3DES hardware encryption
- Embedded TDMA architecture enables real time streaming of high quality audio/video for remote listening, home theatre, and VoIP applications
- Built-in repeating capabilities for increased coverage
- Bridge Forwarding Table for 64 MAC Addresses
- 802.1 Q VLAN & Optimized VLANs
- OFDM technology and powerful error correction system provides robust performance under harsh conditions in the electrical network
- Integrated 802.1D Ethernet Bridge with Optimized Spanning Tree Protocol
- Priority classification according to 802.1 P tags, IP coding (IPv4 or IPv6) or TCP source/destination ports
- Optimized IGMP support for broadcast and multicast traffic

Technical Specifications

Standards Compliance:	IEEE 802.3u 802.1 P/Q	Interface:	10/100BaseT Fast Ethernet Power Outlet 16A* *10A Max recommended
Safety & EMI:	FCC Part 15, EN 55022 EMC limits UL/EN 60950	Speed:	Up to 200 Mbps
Power Input:	100 to 240 VAC, 50/60 Hz	Frequency Range used:	2 - 30 MHz
Power Consumption:	5W	Tx Pwr Spectral Density:	-57 dBm/Hz
Fuse:	FSI, T500mA, 250VAC - to be replaced by authorised personnel only	Dimensions	135 mm L x 66 mm W x 79 mm H
AC Plug Type:	EU	Operating Temperature:	0° to 40°C (32°F to 104°F)
LED Status Lights:	Power on, PLC Link/ Activity Ethernet link	Operating Humidity	10% to 80% non-condensing

Package Contents

- Corinex HD200 Powerline Wall Mount F Adapter (2)
- Standard CAT5 Ethernet Cable (2)
- CD with multi-language user manuals
- Multi-language printed Quick Start Guides - Product Code Specific
- Product Code Specifications:
 - I. -EU - English, French, German and Spanish documentation

Product Specification

Product Code:
CXP-HD200-W2HF EU (2 Pack-European)
Please refer to the Price List for the exact product code specification and details

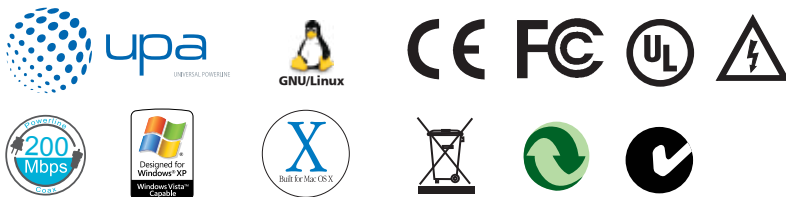
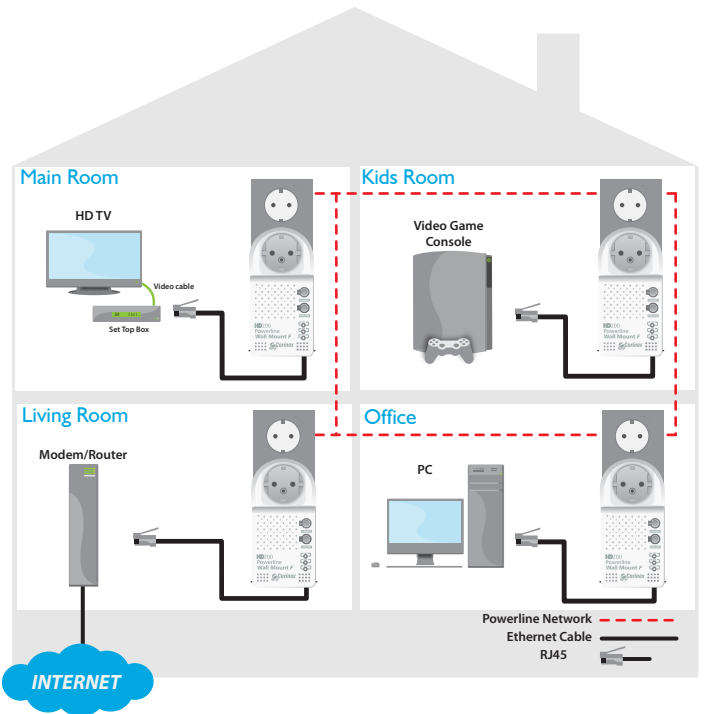
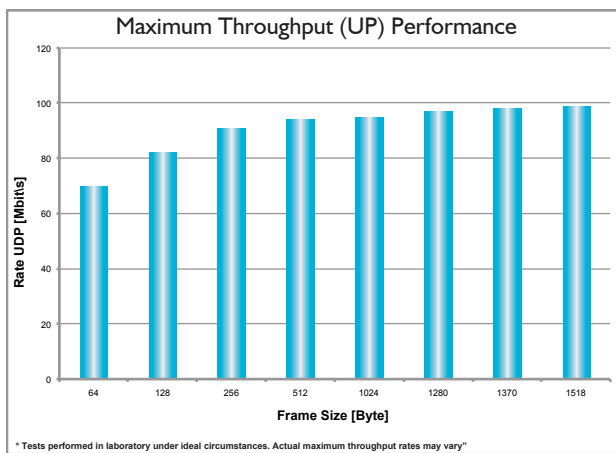

Corinex Communications Corp.
#601 - 905 West Pender Street
Vancouver, BC
Canada V6C 1L6
Tel: 604 - 692 0520
Fax: 604 - 694 0061
E-mail: saleslead@corinex.com

Corinex Communications a.s.
Ambrova 6
821 01 Bratislava 37
Slovak Republic
Europe
Tel.: +421 - 2 - 59 - 212 - 000
Fax: +421 - 2 - 59 - 212 - 222
E-mail: salesleadeu@corinex.com

Corinex is a registered trademark of Corinex Communications Corp.
All products or company names mentioned in here may be the trademarks of their respective owners.
The content of this document is furnished for informational use only, it is subject to change without any commitment on the part of Corinex Communications Corp.

Technical Specifications

Standards Compliance:	IEEE 802.3u 802.1 P/Q	Interface:	10/100BaseT Fast Ethernet Power Outlet 16A* *10A Max recommended
Safety & EMI:	FCC Part 15, EN 55022 EMC limits UL/EN 60950	Speed:	Up to 200 Mbps
Power Input:	100 to 240 VAC, 50/60 Hz	Frequency Range used:	2 - 30 MHz
Power Consumption:	5W	Tx Pwr Spectral Density:	-57 dBm/Hz
Fuse:	FSI, T500mA, 250VAC - to be replaced by authorised personnel only	Dimensions	135 mm L x 66 mm W x 79 mm H
AC Plug Type:	EU	Operating Temperature:	0° to 40°C (32°F to 104°F)
LED Status Lights:	Power on, PLC Link/ Activity Ethernet link	Operating Humidity	10% to 80% non-condensing

Package Contents

- Corinex HD200 Powerline Wall Mount F Adapter (2)
- Standard CAT5 Ethernet Cable (2)
- CD with multi-language user manuals
- Multi-language printed Quick Start Guides - Product Code Specific
- Product Code Specifications:
 - I. -EU - English, French, German and Spanish documentation

Product Specification

Product Code:
CXP-HD200-W2HF EU (2 Pack-European)
Please refer to the Price List for the exact product code specification and details

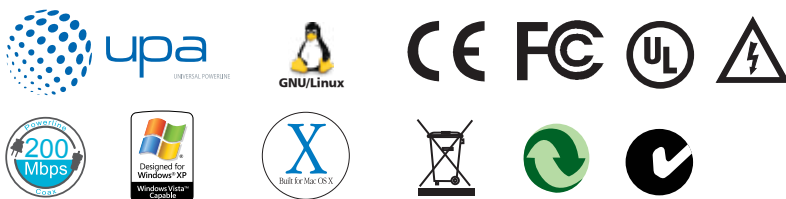
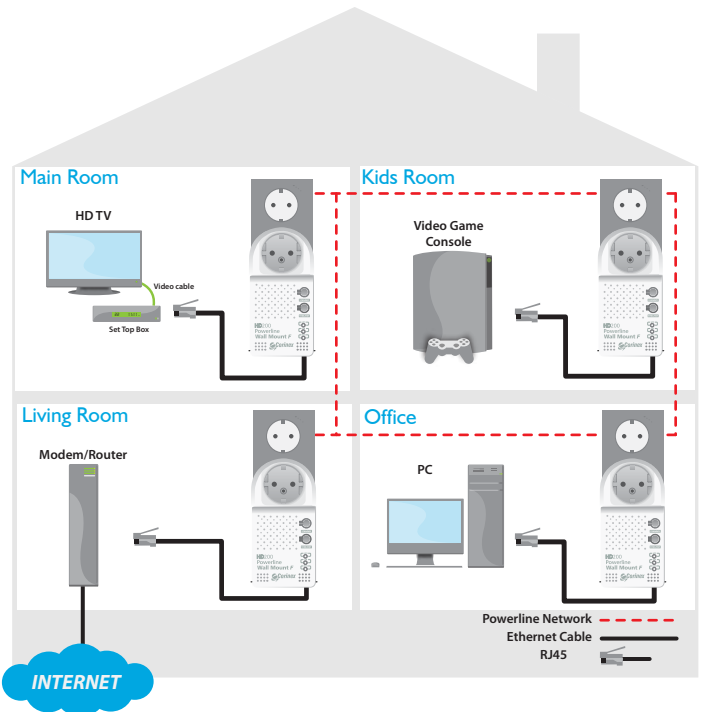
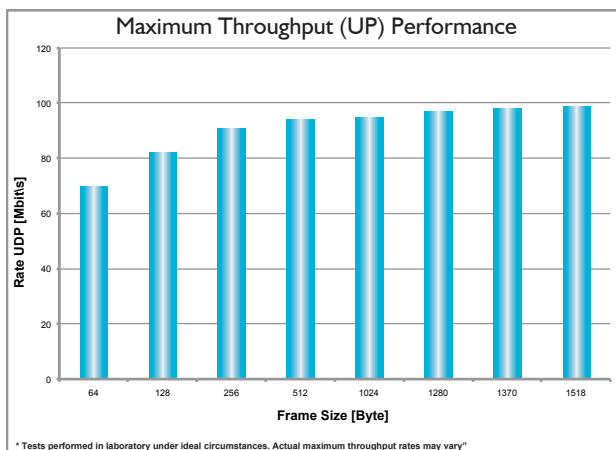

Corinex Communications Corp.
#601 - 905 West Pender Street
Vancouver, BC
Canada V6C 1L6
Tel: 604 - 692 0520
Fax: 604 - 694 0061
E-mail: saleslead@corinex.com

Corinex Communications a.s.
Ambrova 6
821 01 Bratislava 37
Slovak Republic
Europe
Tel.: +421 - 2 - 59 - 212 - 000
Fax: +421 - 2 - 59 - 212 - 222
E-mail: salesleadeu@corinex.com

Corinex is a registered trademark of Corinex Communications Corp.
All products or company names mentioned in here may be the trademarks of their respective owners.
The content of this document is furnished for informational use only, it is subject to change without any commitment on the part of Corinex Communications Corp.